

The future of stormwater management.

PRODUCT GUIDE · 2026

30
1996 – 2026

30 YEARS
OF SMARTER
STORMWATER
MANAGEMENT

Stormwater**360**[®]



Stormwater360 proudly holds the distinction as New Zealand's pioneers in stormwater solutions and the first company to focus on stormwater management in the country, with over 30 years of unmatched experience and expertise.

Our company's products address the impacts of urban growth with a range of natural and engineered stormwater solutions.

By screening plastic and other gross pollutants, filtering sediment, absorbing heavy metals, enhancing evapotranspiration and increasing infiltration, we can reduce the impact of stormwater runoff on our environment.

We are passionate about our waterways and are committed to delivering stormwater solutions that preserve and protect the future of our rivers, lakes and oceans.

The right technology
for your project.

Contents

Green Infrastructure

RUNOFF REDUCTION / FLOW CONTROL/SEDIMENT/NUTRIENTS

Filterra®	4
Filterra® Bioscape®	5
Grasscrete™	6
LiveRoof®	7
ChamberMaxx™	8

Filtration

HEAVY METALS / NUTRIENTS / FINE SEDIMENT

StormFilter™	9
Jellyfish®	10

Diversion & Oil/Water Separation

DIESEL / PETROL / HYDROCARBONS / SPILL CONTROL

ESK™ Oil Management System	11
Fox™ Valves	12

Hydrodynamic Separators, GPTs and inserts

PLASTIC / GROSS POLLUTANTS / SEDIMENT

VortCapture™	13
Cascade Separator™	14
Vortechs™	15
EnviroPod®	16
LittaTrap™	17

Product Selection Guide	18
360 Maintenance	19

Filterra®

Market leading biofiltration system with a small footprint.

Biological treatment system that will remove the majority of contaminants, reduce stormwater flows and blend in to the urban environment.

Developed after decades of research, Filterra® is a next-generation biofiltration solution, designed to provide enhanced treatment outcomes while requiring as little as 10% of the footprint of traditional rain gardens.

Filterra® is a pre-engineered and manufactured plug-and-play micro biofiltration system that removes TSS, metals and nutrients using natural, biological processes. Designed to treat up to 4450mm/hr and with a maximum treatable flow rate of 8230mm/hr (WADOE Approval) the Filterra® media has been optimised to operate under high flow rates while maintaining high pollutant removal performance. The Filterra® engineered media is designed for low maintenance and does not need replacing under normal conditions, making it one of the most cost-effective treatment devices to maintain.



Key Benefits

- Delivered as a plug and play solution.
- Cost efficient - Low life cycle cost.
- Small footprint - fraction of the size of traditional raingardens.
- Proven and verified performance.
- Media does not need replacing.
- Enhanced dissolved heavy metal removal.
- Increased biodiversity.

Very High Sediment Removal

WINNER 2022

Water NZ Innovation Award
Filterra® Roof

Approvals

- ✓ Auckland Council Approved for use on public and private sites.
- ✓ Christchurch City Council Approved for use on public and private Sites.

Configurations

- Filterra® Bioscape
- Vault Filterra®
- Manhole Filterra®
- Roof Filterra®



Based on a comparison of a traditional designed raingarden (k=0.3-0.75m/d) and the Filterra® (k=2.5m/h).

Maintenance

- Easy maintenance with no confined space access.
- First year maintenance included.

For Filterra® models and sizing visit <http://design.stormwater360.co.nz>

Filterra® Bioscape®

A solution for large, high performance biofiltration.

Stormwater360 Filterra® Bioscape® is an engineered, centralised biofiltration system, designed to treat catchments over 10,000m². It uses the patented Stormwater360 Filterra® technology to deliver best-in-class treatment on a small footprint.

Green infrastructure has been used for decades to provide excellent treatment and ecological outcomes. A manufactured system providing market-leading enhanced treatment outcomes, the Filterra® Bioscape® requires as little as 10% of the footprint of conventional treatment devices.

Filterra® Bioscape® is a collaboration between Stormwater360 and design consultants, placing the proven Filterra® technology into custom-designed, large format, built-in situ encasements. Custom-designed flow distribution makes sure every part of the Filterra® Bioscape® is providing treatment, and full integration into any landscape design is possible. Whereas ponds and wetlands need rebuilding periodically, the Filterra® Bioscape® media should not need replacing.



Key Benefits

- Shaped to match surroundings.
- Cost efficient - Low life cycle cost.
- Small footprint - fraction of the size of traditional raingardens.
- Proven and verified performance.
- Media does not need replacing.
- Enhanced dissolved heavy metal removal.
- Increased biodiversity.

Very High Sediment Removal

Approvals

- ✓ Auckland Council
- ✓ Christchurch City Council
- ✓ Accepted nationwide.

Maintenance

- Easy maintenance with no confined space access.
- First year maintenance included.

Applications

- ✓ Greenfield and brownfield developments.
- ✓ Residential subdivisions.
- ✓ Mixed-use and commercial subdivisions.
- ✓ Local roads and highways.
- ✓ Catchments over 1ha.



Grasscrete™

Load-bearing, reinforced concrete permeable pavement.



LiveRoof®

New Zealand's only pre-vegetated modular green roof system.



Engineered permeable surfaces are an 'at-source' Water Sensitive Design (WSD) feature to reduce stormwater runoff volumes via infiltration and evapotranspiration.

Grasscrete™ from Stormwater360 is a cast-on-site cellular reinforced concrete permeable paving system that is an effective Water Sensitive Design (WSD) solution to reduce impervious surfaces and promote infiltration.

Stormwater regulation limits the number of impermeable surfaces on a property; Grasscrete™ permeable paving allows for a greater building footprint.

Key Benefits

- Easy to install.
- Reduce impervious areas.
- Withstands heavy vehicle loadings.
- Reduces stormwater volume.
- Increase building footprint and functional space.
- Reduces concrete by 40%.
- Cost efficient.



Engineered permeable surfaces are an 'at-source' Water Sensitive Design (WSD) feature to reduce stormwater runoff volumes via infiltration and evapotranspiration.

LiveRoof® is New Zealand's only pre-vegetated modular green roof system, specifically designed to grow plants in a rooftop environment.

With plants already grown before installation, establishment and maintenance costs are reduced as the roof is fully-grown when installed. The LiveRoof® modular green roof system uses Stormwater360's compliant green roof soil media and has numerous New Zealand native or sedum/succulent planting options.

Key Benefits

- Pre-vegetated before installation ensuring maximum visual impact immediately.
- Full design services using a complete range of native and succulent green roof plants.
- Cost-effective solution.
- Reduced establishment costs.
- Low ongoing maintenance costs.
- Designed for roof pitches up to 30 degrees.
- Ideal for both residential and commercial builds.
- Reduces temperature fluctuations.
- Increased biodiversity.
- Stormwater management through volume reduction.

Approvals

- ✓ Acceptance of compliance with New Zealand Building Code (Auckland Council).

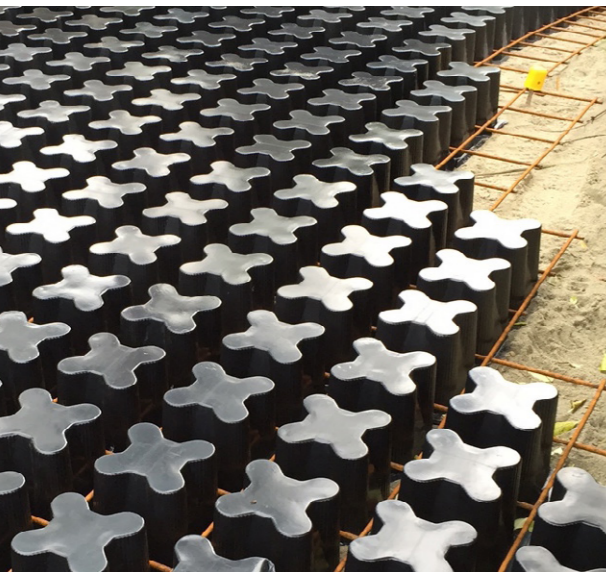

ChamberMaxx™

Retention, detention or underground reuse tank.

Stormwater chambers allow both retention and detention of stormwater so they can be used as either a traditional stormwater management tool combined. In detention applications, the chambers can be sealed with an impermeable membrane to create an underground waterproof tank structure, and is ideal to maximise storage capacity in a shallow footprint.

The ChamberMaxx™ corrugated, open-bottom plastic infiltration chamber system allows you to meet stormwater runoff reduction requirements and maximise available land space by providing economic infiltration below ground. ChamberMaxx™ maximises storage volume in a small footprint, and its low profile shape is ideal for sites with shallow footprints or where land is at a premium.

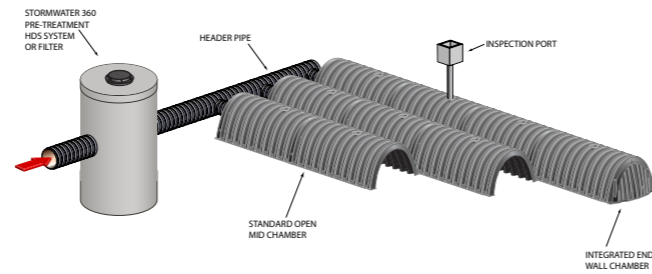

For ChamberMaxx™ models and sizing visit <http://design.stormwater360.co.nz>

Key Benefits

- 2.1m³ of storage per chamber.
- Easy installation - no heavy lifting equipment required.
- Lightweight, low profile shape (770mm rise).
- Meets New Zealand Heavy Traffic Loading (HN-HO-72) standards.
- Modular configuration with flexible layout options.
- Efficient space utilisation.
- Structural integrity and durability.

Applications

- ✓ Detention
- ✓ Retention
- ✓ Soakage
- ✓ Rainwater Harvesting
- ✓ Install under raingardens for reduced footprint in volume reduction regulated areas.

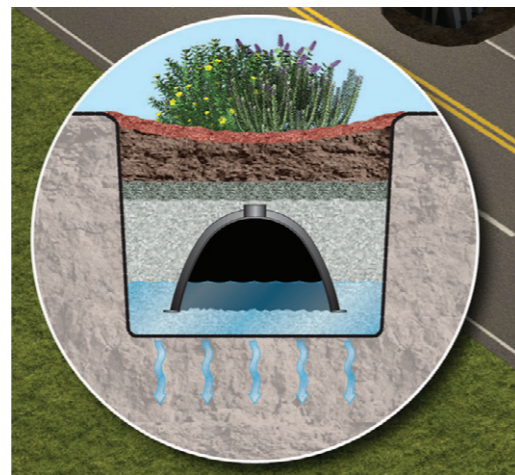

Reduce Auckland Council SMAF zone raingarden size.

StormFilter™

Siphon-actuated filtration.

Our stormwater treatment filtration devices have been developed to remove an array of contaminants, including sediment, heavy metals and nutrients to meet the most stringent regulatory authority requirements.

The Stormwater Management StormFilter™ cleans stormwater through a patented passive filtration system, effectively removing pollutants to meet the most stringent regulatory requirements. Easy to install and maintain, with proven performance over time, the StormFilter™ contains rechargeable, media-filled cartridges that remove a variety of pollutants, such as sediments, oil and grease, metals, organics, and nutrients. These systems come in variable configurations to match local conditions and come with prolonged maintenance periods to ensure long-term performance and reduce operating costs.

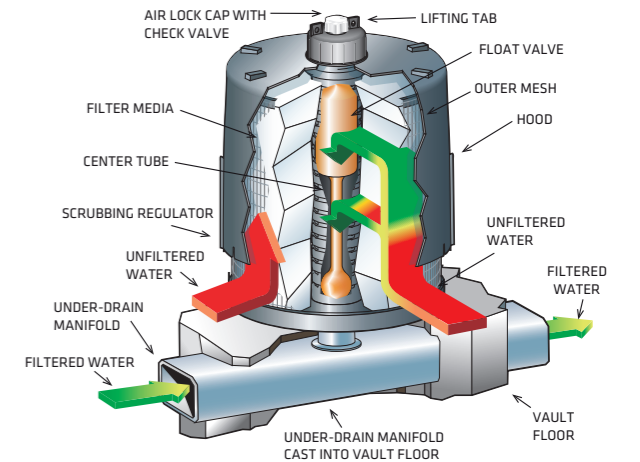

For StormFilter™ models and sizing visit <http://design.stormwater360.co.nz>

Key Benefits

- Easy maintenance and low life cycle costs.
- Can be configured in any drainage structure.
- Customised media options including ZPG, Perlite, Zeolite and GAC target TSS, phosphorus, heavy metals, and hydrocarbons.
- Multiple cartridge heights give design solutions for site restraints.

High Sediment Removal



Maintenance

- Every 2-5 years.
- Cartridge Exchange Service.
- Lifetime warranty on StormFilter™ cartridges (conditions apply).

Approvals

- ✓ Auckland Council Approved for use on Public and Private Sites.
- ✓ Christchurch City Council Approved for use on Public and Private Sites.
- ✓ Accepted nationwide.

Superior Hydraulics

Multiple cartridge heights give design solutions for site restrictions.

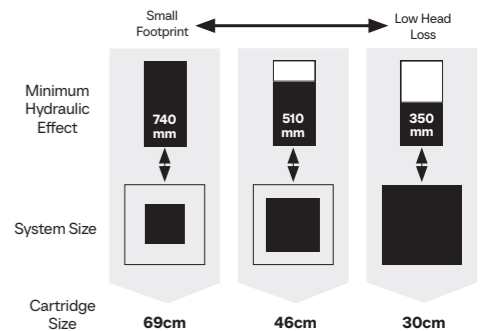



This revolutionary stormwater quality device is the latest in filtration technology and uses gravity, flow rotation, and up-flow membrane filtration to provide stormwater treatment in an underground compact stand-alone system.

Using unique filtration cartridges, each Jellyfish® Filter has a large membrane surface area, resulting in high flow rates and pollutant removal capacity. The filter has a number of 'tentacles' that catch and remove floatables, litter, oil, debris, TSS, silt-sized particles (as small as 2 microns), and a high percentage of particulate-bound pollutants; including phosphorus, nitrogen, metals and hydrocarbons.

The Jellyfish® Filter has a much smaller footprint than other best-management practices (BMPs), greater design flexibility and no replaceable media.

Key Benefits

- High surface area, high flow rate membrane filtration.
- Highest design treatment flow rate per cartridge with adjustable headloss of 150- 457mm headloss.
- Lightweight cartridges with passive backwash.
- Ideal for flat land areas with hydraulic restriction.

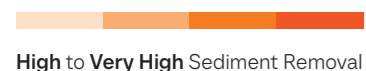

Maintenance

- Low maintenance costs.
- Reusable cartridges.
- No replaceable media.

Approvals

- ✓ Auckland Council Approved for use on public and private sites.
- ✓ Christchurch City Council Approved for use on public and private sites.
- ✓ Accepted nationwide.

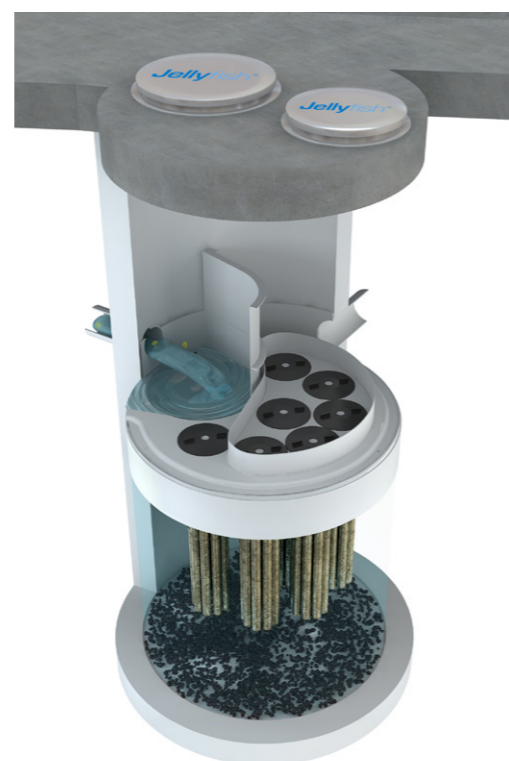

Jellyfish® Filter

For Jellyfish® models and sizing visit <http://design.stormwater360.co.nz>



Stormwater360 offers a range of solutions for industrial sites and trade-waste applications. Our products help you meet regulations by capturing oil in stormwater, keeping it on-site and away from the environment.

ESK™ Oil Management System

The ESK™ is a passive high efficiency coalescing separator that removes free oil from contaminated stormwater runoff and has a built-in shutoff valve to prevent spills and storage capacity excess exiting the device. The device is ideally suited for sites where specific effluent targets are specified, or for sites where removal of oil and grease is the greatest concern e.g. fuel stations, fuel distribution stations, car servicing workshops, etc. It is typically sized to remove oil droplets as small as 10 microns and achieve an effluent concentration of 5 mg/L or less.

Key Benefits

- Easy to install and maintain.
- Reusable and washable media.
- Optional alarm system, sensor control, remote control.
- Small footprint.

Maintenance

- Easy to maintain.
- Reusable and washable media.

Applications

- ✓ Refueling stations
- ✓ Farms
- ✓ Petrol Stations
- ✓ Industrial Sites
- ✓ High contaminating activities

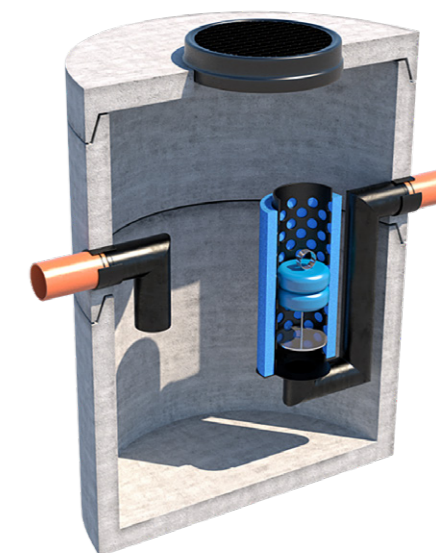

For ESK™ models and sizing visit <http://design.stormwater360.co.nz>



Treatment Train

With industrial sites, often the runoff is highly contaminated and cannot be managed through source control measures. In such instances, several treatment devices can be used in a "treatment train". Each device in the treatment train targets a different contaminant. Often a treatment train is required to lower the concentration of contaminants to a suitable level for safe discharge. In many cases a treatment train is used to lower operational costs.

Available Models

ESK™	Chamber Diameter m	Treatment Flow L/s	Recommended Inlet/Outlet Pipe Size mm
ESK10	1050	10	150
ESK20	1200	20	200
ESK40	1500	40	300
ESK100	1800	100	300

Our standard ESK™ coalescing separator range is designed and manufactured for treatment flows starting at 1.5L/s up to 100L/s.

Fox™ Valves

Divert harmful pollutants washdown away from stormwater.



FOX™ Diversion Valves

The Fox™ Valve system is a stormwater/tradewaste diversion system designed to divert washdown and/or first flush stormwater runoff to trade waste to prevent pollution of downstream water bodies. Stormwater360 can supply different models depending on application and contaminant of concern.

Key Benefits

- Plug and play.
- Designed for sites over 5m².
- Hydraulically operated - wastewater diversion works even without power.
- Trafficable – Heavy Duty CLASS D grate.

Applications

- ✓ Aviation/Airports
- ✓ Earthmoving
- ✓ Armed Forces
- ✓ Ports
- ✓ Marinas
- ✓ Fuel/Gas Stations
- ✓ Mining
- ✓ Slipways
- ✓ Trucking/Transport
- ✓ Vehicle Dealerships

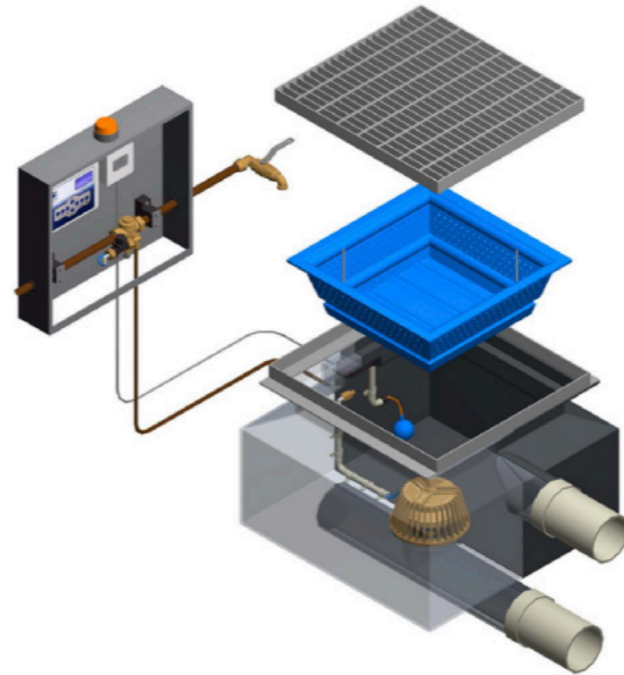

Available Models

Unit	Description	Applications	Need Power
FOX DD600	Demand Driven - this system relies on the work area being left free from pollutants after the washdown activity has ceased.	Machine washdown, small wash areas that can be kept clean after use, car wash areas etc.	No
FOX FF600	First Flush - for washpads where the area may be left polluted after the wash down operation ceases.	All washpads that are dirty and can't always be left clean.	Yes (240v 10 amp)
FOX SCS600	Spill Control System - provides total protection for pollutants "on the water".	Liquid sites such as Service Stations and re-fueling areas.	Yes (240v 10 amp)
FOX CMS600	Constant Monitoring System - provides total protection where pollutant is water soluble.	Milk Depots, Wineries and Chemical Plants.	Yes (240v 10 amp)



VortCapture™

Full capture gross pollutant trap with internal bypass.



Gross pollutant control plays an important role in stormwater management. From targeting visual contaminants such as plastic, litter, leaves or oils, to pre-treatment of sediments prior to filtration devices, ponds or wetlands. Gross Pollutant Traps (GPT's) are a cost-effective way to reduce your site's contaminant loadings and extend system maintenance frequencies.

VortCapture™ is a full capture, high-capacity litter, debris & sediment solution designed to remove all particles greater than 5mm in size. The system combines the proven sediment removal capability of hydrodynamic separation with superior litter and organic debris capture. The result is a stormwater treatment system that effectively captures and retains a broad range of pollutants.

Key Benefits

- Integrated high-flow diversion.
- Flexible, compact design ideal for congested sites.
- Provides unobstructed access to stored pollutants, making it easy to maintain.
- Integrated screen to 100% remove neutral buoyant debris.

Moderate Sediment Removal

Applications

- ✓ Ideal for pretreatment – reduce maintenance costs on downstream stormwater device.

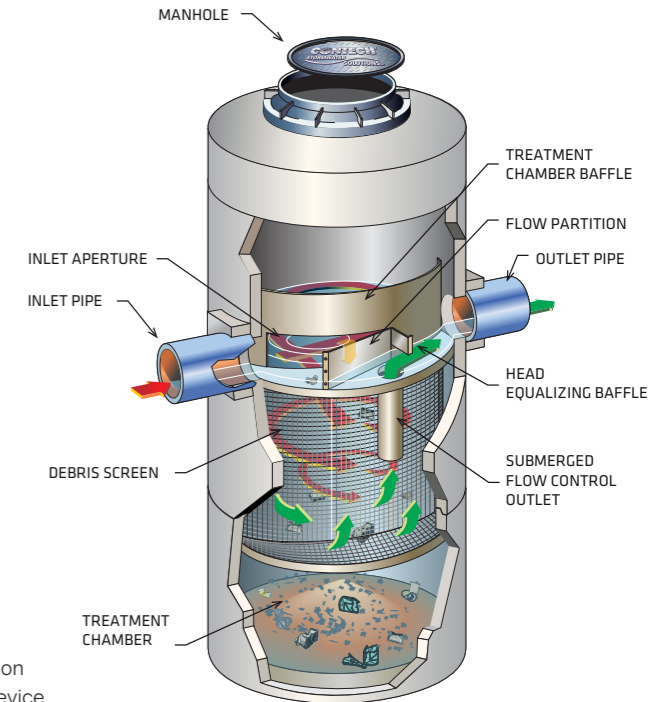

For VortCapture™ models and sizing visit <http://design.stormwater360.co.nz>

Cascade Separator™

Innovative and efficient hydrodynamic separator.



The Cascade Separator™ is the newest innovation in stormwater treatment. This innovative hydrodynamic separator excels at sediment capture and retention while also removing hydrocarbons, litter, and debris from stormwater runoff.

What makes the Cascade Separator™ unique is the use of opposing vortices that enhance particle settling and a unique skirt design that allows for sediment transport into the sump while reducing turbulence and resuspension of previously captured material. These two factors allow the Cascade Separator™ to treat high flow rates in a small footprint, resulting in an efficient and economical solution for any site.

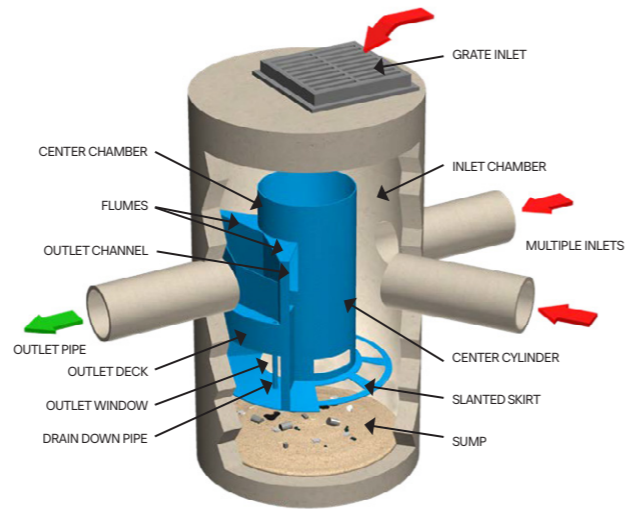

Key Benefits

Unique skirt design that prevents scouring with opposing vortices resulting in superior TSS removal.

Accepts a wide range of inlet pipe angles allowing for design and installation flexibility.

Accepts multiple inlet pipes eliminating the requirement and cost for upstream receiving manholes.

The grate inlet option eliminates the need for a separate grate inlet structure.

Internal bypass saves the requirement and cost of upstream bypass structures.

Clear access to storage sump provides fast and easy maintenance.

Range of sizes available.

Moderate Sediment Removal



Vortechs™

Hydrodynamic separator for shallow applications.

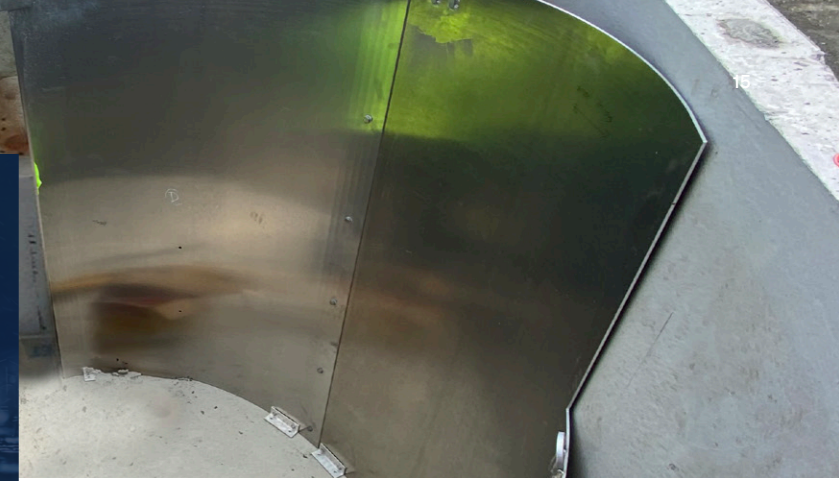

The Vortechs™ system is a high-performance hydrodynamic separator that effectively removes fine sediment, oil and grease, and floating and sinking debris.

Its swirl concentrator and flow controls work together to minimise turbulence and provide stable storage of captured pollutants. The design also allows for easy inspection and unobstructed maintenance access. With comprehensive lab and field testing, the system delivers proven results and site-specific solutions.

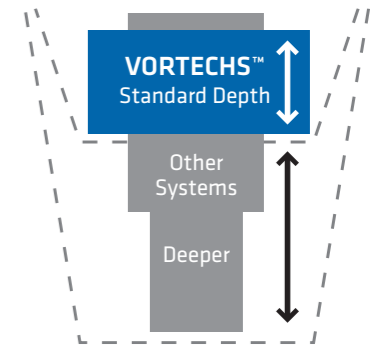

Key Benefits

High removal rate of fine sediments.

Compact design to reduce cost and sprawl.

Largest treatment zone surface area of any hydrodynamic system available.

Easy maintenance – unobstructed access to stored pollutants.

Proven performance verified through third-party testing.

The shallow system profile and unique horizontal design make installation easier and more cost-effective.

Flexible design fits site constraints and accommodates a wide range of treatment options.

Adjustable headloss.

Moderate Sediment Removal

Applications

✓ Ideal for larger projects.

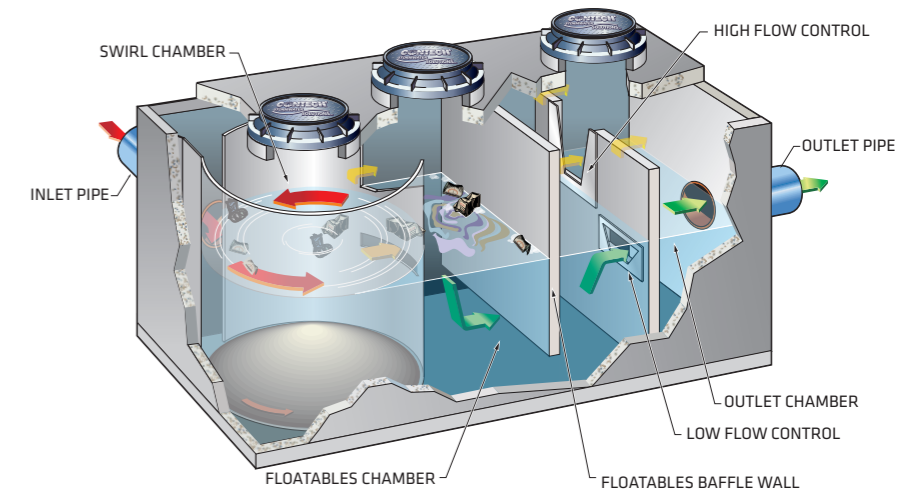

EnviroPod® Filter

Cost-effective, easily maintained catchpit insert.



A low-cost solution that involves inserting a screening and sedimentation device into new or existing catchpits. Capturing pollutants at source allows hotspot targeting and can reduce maintenance costs for downstream stormwater treatment devices and infrastructure.

The EnviroPod® Filter is an effective, easily maintained catchpit insert that captures and retains litter, debris and other pollutants as runoff enters the storm drain system. This catchpit insert can be installed in either a curb inlet or drop-in catchpit and can be customised to meet site-specific requirements. The EnviroPod® Filter is effective as a pre-treatment device in a treatment train and is often the most practical solution for retrofits.

Key Benefits

- High-performance catchpit insert.
- No construction (retrofitable) is required resulting in low costs.
- Various sizes are available and can be custom-designed.
- Can be used to easily target heavily polluted areas.
- Fine precision woven screen to capture smaller particles e.g. sediment, plastic pellets, turf rubber.
- Other filter bags available for targeted contaminants.

Moderate Sediment Removal

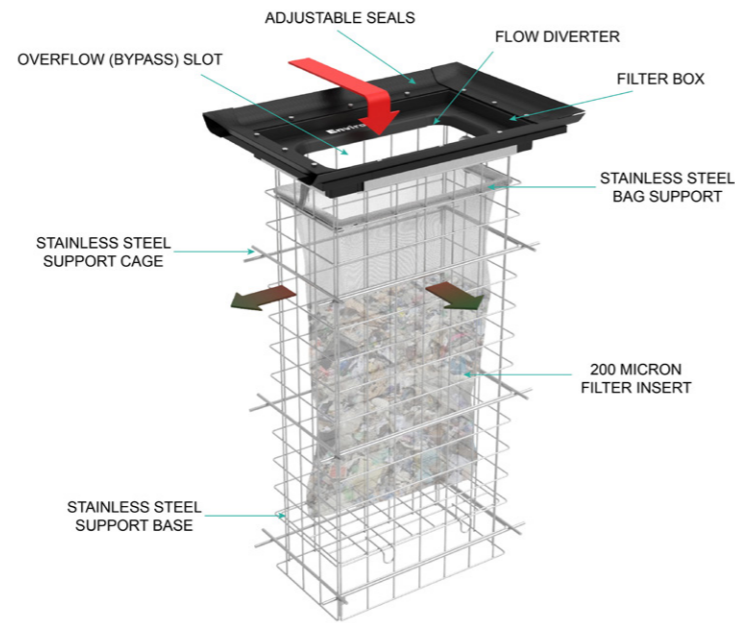

Applications

- ✓ Pretreatment.
- ✓ Litter capture.



LittaTrap™

Low-cost catchpit insert for removal of litter and gross pollutants from run-off.



The LittaTrap™ is a cost-effective, innovative catchpit insert designed to be easily retrofitted into new and existing stormwater drains to specifically target litter, plastic and gross pollutants over 5mm.

The LittaTrap™ has patented flow-modifying components that dissipate energy, promote Total Suspended Solids (TSS) capture in sumped catchpit, and provide full capture of gross solids.

Key Benefits

- Easy hand maintenance.
- Easy to install.
- Lightweight for easy handling.
- Various sizes are available and can be custom-designed.
- Optional liners for targeted contaminants e.g. sediment, plastic pellets.

Moderate Sediment Removal

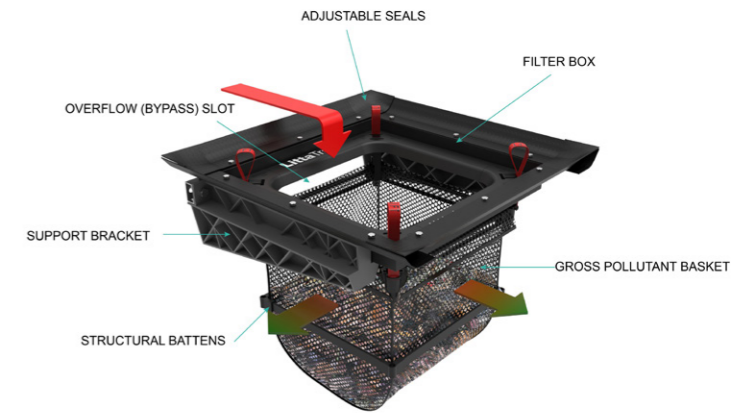

Applications

- ✓ Pretreatment.
- ✓ Litter capture.



The LittaTrap™ is easily maintained by hand

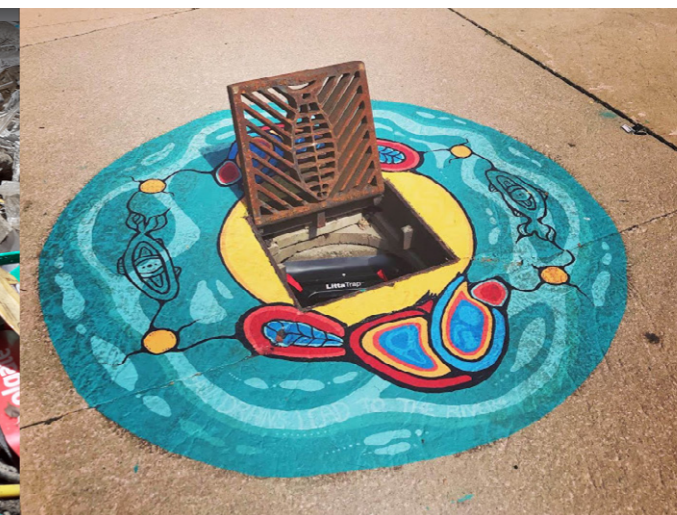
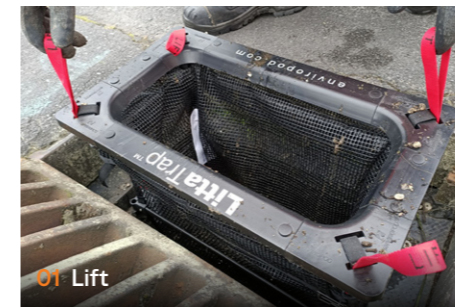

Stormwater360 Device Selection Guide

Stormwater can have a range of contaminants entrained in the runoff and Stormwater360 treatment devices target these various contaminants in their different forms. When it comes to designing your stormwater solution, our experienced team will offer advice and assistance and provide you with the best solution for your needs.

Stormwater360 Treatment Products Performance Matrix

	Floatable Gross Pollutants	Neutrally Buoyant Gross Pollutants	Free Oil	Heavy Metals/ TSS			Dissolved Contaminants
				Moderate	High	Very High	
StormFilter™ (Perlite)	✓	✓	✓		✓		
StormFilter™ (Phosphosorb)	✓	✓	✓		✓		✓
StormFilter™ (ZPG)	✓	✓	✓		✓		✓
Jellyfish® Filter	✓	✓	✓			✓	
ESK™			✓				
VortCapture™	✓	✓		✓			
Cascade Separator™	✓		✓	✓			
Vortechs™	✓		✓	✓			
EnviroPod® Filter	✓	✓		✓			
LittaTrap™	✓	✓		✓			
Filterra®	✓	✓	✓			✓	✓

Operation and Installation Considerations

Often operational considerations influence the decision as to which treatment devices should be used.

	Installation Cost	Maintenance Cost	Shallow Install	Replaceable media	Hydraulic Requirement
StormFilter™	Medium	Medium	✓	✓	0.35m - 0.9m
Jellyfish® Filter	Low	Medium			0.15m - 0.45m
VortCapture™	Medium	Low – Medium			0.25m - 1m
Cascade Separator™	Low	Low – Medium	✓		0.25m - 1m
Vortechs™	Low	Low – Medium	✓		0.25m - 1m
EnviroPod® Filter	Low	Medium	✓		Min (pipe cover)
LittaTrap™	Low	Low	✓		Min (pipe cover)
Filterra®	Low	Low	✓	✓	Min (pipe cover)

Retain performance and compliance with 360 maintenance.

At Stormwater360, operational maintenance is not just a routine task; it's a commitment to the long-term performance and sustainability of our solutions.

As a testament to our dedication to stormwater treatment, we're proud to introduce our new Operations and Maintenance Training Programme for various Stormwater360 devices. This programme offers invaluable knowledge for asset managers and maintenance contractors alike.



Why regular maintenance is essential.



Preempt device damage

Stormwater structures or storage facilities can become clogged with debris or sediment, leading to reduced flow or storage capacity, which in turn may result in flooding of the site and damage to stormwater assets.



Maintain efficiency

A reduction in the ability of stormwater treatment devices to efficiently and effectively remove and prevent pollutants from entering waterways.



Ensure compliance

A failure to comply with local authority regulations relating to stormwater quality standards, which may result in penalties for the site's owners or property managers.



Avoid device failure

The likelihood of costly repairs, increased ongoing maintenance costs and the potential of damage to other infrastructure or drainage assets.

Operation and Maintenance Certification training programme.



WHAT YOU WILL LEARN:

Routine Inspection Procedures

Learning how to conduct regular checks and identify potential issues.

Preventive Maintenance

Acquiring skills to perform preventive maintenance tasks to prolong the lifespan of Stormwater360 devices.

Troubleshooting Techniques

Developing abilities to diagnose and resolve common operational challenges.

Certification upon Completion

At completion of this course, you will become a certified maintenance provider of your chosen Stormwater360 devices.



To work out which solution is right for your project talk to the Stormwater360 team or use our online design sizing calculator.

Visit www.stormwater360.co.nz

To enrol into our maintenance training email maintenance@stormwater360.co.nz or Freephone 0800 STORMWATER (0800 786 769).

BETWEEN SKY
AND
SEA



Filterra® Bioscape®
Auckland

©2026 Stormwater360 Nothing in this brochure should be construed as an expressed warranty or an implied warranty of merchantability or fitness for any particular purpose. See the Stormwater360 standard quotation or acknowledgement for applicable warranties and other terms and conditions of sale.

The product(s) described may be protected by one or more of the following US, Australian and New Zealand patents : 583,461; 588,049; 604,227; 5,322,629; 5,624,576; 5,707,527; 5,759,415; 5,788,848; 5,985,157; 6,027,639; 6,350,374; 6,406,218; 6,641,720; 6,511,595; 6,649,048; 6,991,114; 6,998,038; 7,186,058; 7,296,692; 7,297,266; related foreign patents or other patents pending. StormFilter™, Jellyfish™, ESK™, LittāTrap™, EnviroPod®, VortCapture™, VortSentry HS™, Vortechs™, Fox™ Valves, ChamberMaxx™, Filterra®, LiveRoof® & GrassCrete™ are trademarks, registered trademarks, or licensed trademarks of Stormwater360®.

0800 STORMWATER (0800 786 769)
Stormwater360.co.nz

Stormwater360®

The future of stormwater management.

PRODUCT GUIDE · 2026

Leading the way in advancing stormwater management.

30
1996 – 2026

30 YEARS
OF SMARTER
STORMWATER
MANAGEMENT

Stormwater**360**[®]

The future of stormwater management.

Three decades of innovation.
Engineered for what's next.



30
1996 – 2026

30 YEARS
OF SMARTER
STORMWATER
MANAGEMENT

Stormwater**360**[®]